

English Version of the [Original Article](#)

Cite as: Baltacı, A. (2020). Doğum Teminatı Sigortası Tercihinde Hamilelikte Risk Algısının Etkisi: Kadın Tüketiciler Üzerine Bir Araştırma. Bankacılık ve Sigortacılık Araştırmaları Dergisi, (14), 26-43.

Retrieved from:

<https://dergipark.org.tr/tr/pub/bsad/issue/55816/734539>

Pages are synchronized with the original article.

Effect of Perceived Risk at Pregnancy on the Maternity Insurance Choice: A Research on Female Consumers

Abstract

The purpose of this research is to understand the thoughts of female consumers about maternity insurance within the frame of perceived risk at pregnancy and developing a valid scale about the concept. For achieving this, a quantitative questionnaire form has been composed and delivered online. 472 valid form has been obtained. Frequency, factor, confirmatory factor, and reliability analysis have been applied to the collected data. After all; a structurally valid measurement tool has been obtained which has 4 dimensions, 14 items with high reliability. Additionally, it has been understood that women think they would feel safer and having a better pregnancy if they buy maternity insurance.

Keywords: Maternity insurance, perceived risk, pregnancy, female consumer, birth assurance

JEL Classification: G22, I12, M31

INTRODUCTION

With the increasing number of private enterprise healthcare providers, the insurance sector also kept in pace with that situation. Collateral health insurance is one of the most substantial instruments of the insurance companies.

Risk is defined as “a possibility of bad results on the issues that an individual attaches importance” (Aven and Renn, 2009: 6). Perceived risk a structure that varies from person to person and that differs from actual risk (Pilarski, 2009). Bauer was the first researcher who defined the perceived in 1960 and indicated that it is a structure with two dimensions; uncertainty and negative outcomes. Weinstein et al. (2007: 147) defined the concept as a person’s expectation for an adverse event to come true. According to Brewer et al. (2007: 136), perceived risk is a belief about possible

losses. On the other hand, Pilarski (2009) asserted that the perceived risk is a complex issue that hasn't been clearly understood yet. The raison d'être of the insurance sector is compensating for the possible losses for the insureds.

This research investigates the effect of the perceived risk on the maternity insurance preferences of women.

1.LITERATURE REVIEW

1.1.Maternity insurance

Orhaner (2000: 76) says “private insurance is a kind of insurance that bears the expenses of an individual's medical examinations, treatments and medications even that individual may or may not have another insurance”.

Collateral health insurance (CHI) is also a kind of private insurance. CHI “is a kind of insurance that covers the risks about the expenses of health problems, with various options” (Erkek and Erkek, 2012: 79; Cited by: Özer et al., 2014: 4). According to Foubister et al. (2006: 3; Cited by: Önder et al., 2006: 28). CHI emerged to overcome the deficiencies of social security systems. Thereby, private health insurances may play a subsidiary role in covering some expenses that are not covered by social security (Önder et al., 2016: 28).

Birth assurance is a kind of insurance that has to be signed before the birth which includes the expenses of pregnancy tests, contraception, physician examinations, birth, abortion, and the complications of pregnancy (Atalay, 105).

According to the shared information on the web sites of Turkish insurance companies, maternity insurance is a kind of collateral insurance that covers the phase of pre-pregnancy to the after-birth phase. The intersection of this information on the websites of the Turkish insurance companies (Anadolu Sigorta, Halk Sigorta, Allianz, Acıbadem, Demir Sağlık, Türk Nippon, Ray Sigorta) is:

- Normal delivery,
- Abdominal delivery,
- Routine controls,
- Physician examinations,
- All kinds of treatments for the complications of pregnancy,
- Medicaments,
- Laboratory services,
- Medical imaging services.

These companies are also announcing an offer that combines maternity insurance and newborn insurance for their consumers. Newborn insurance includes services as; vaccines, medical tests, and physician examinations.

From the perspective of women maternity insurance is a tool that can help them to decrease the risks of pregnancy and having proper medical treatment. Under these circumstances, we are expecting that it may have a significant influence on both perceived and actual risks.

1.2. Perceived Risk

Many different theories in the literature try to define the perceived risk. Cultural Theory and Psychometric Theory are the most prominent ones.

Cultural Theory was developed by Douglas and Wildavsky in 1982. This theory hypothesizes that perceived risk is surrounded by social and cultural frames. Cultural Theory also asserts that the values, attitudes, and ethos are shaped by their social environment. The result of this combination helps people to perceive and evaluate the risk (Douglas ve Wildavsky, 1982).

According to Cultural Theory, there are four kinds of people depending on their understanding of risks. Some people are more sensitive for the technological and environmental risks (egalitarians), some others are delicate to the market competition and threats (individualists), some other people are law and order oriented (hierarchical), and the last group is the ones that are immune to all kinds of risks (determinists) (Sjoberg, 2000). According to this theory, people would hesitate or not hesitate about behavior based on their socially shared ethos. These ethe are known as cultural biases, and they include the individual perceptions of the people (Wildavsky ve Dake, 1990; Dake, 1992).

The psychometric model is focusing on cognitive factors. There are two principal cognitive factors according to the assumption of this theory. These factors are unknown risk factors and formidable risk factors (Slovic et al., 1980; Slovic, 1987). This theory asserts that risk is not a concept that waits out there to be measured independent from our culture and thoughts (Slovic, 1992: 119). The psychometric model was introduced by Fischhoff et al. in 1978. This research studied the risk upon the nine characteristics. These characteristics are; voluntarily risk-taking, innovativeness, the immediacy of the impact, communal knowledge about the risk, knowledge of the scientists, control over the risk, possible devastating results of the risk, severity of the results of the risk, and general fear from the risk. Research by Fischhoff et al. (1978) founds highly correlation between all these characteristics. Later, they reduce these characteristics under two dimensions; the level of uncertainty of the risk and avoidance level generated by the risk (Fischhoff et al., 1978; Gerend et al., 2004).

According to the literature, perceived risk is a multi-dimensional structure that is a result of the social, political, and cultural environment of the people (Slovic, 1992). Although experts are trying to define the perceived risk by different statistical methods, it is a structure that is affected by uncountable variables (Boholm, 1998). Mostly applied variables by researchers are culture, risk congruity, social factors, risk affinity, perceived control over the risk, trust in the resource of the information, age, and sex.

Social and cultural resources are substantial for the risk perception (Weyman and Kelly, 1999). As mentioned in the cultural theory, the social structure has a substantial role in specifying the values and behaviors of people. Therefore, different context-dependent cultural and social values have different impacts on the perceived risk (Douglas and Wildavsky, 1982).

Risk affinity is a dimension that describes the level of familiarity of a person for risk. Risk affinity is also a subcomponent of the unknown risk concept. Risk affinity is about the past experiences, information level for the risk, and the perceived control level over the risk (Williamson and Weyman, 2005).

Risk congruity is another issue that affects the perceived risk. Individual or non-individual experiences (like the information obtained from social media or witnessing someone's experience) may affect the level of the perceived risk congruity. That is also called the level of possibility (Gerend et al., 2004).

Risk affinity is a reliable determinant for evaluating the possibility of an incident. According to Kahneman and Tversky (1973: 237), people may foresee the results of the incidents better when they are in accord with the incident. In other words, people would evaluate the possibility of an incident with a comparison between their characteristics and the incident (Gerend et al., 2004).

Perceived control is an output of the cognitive evaluation of an individual. According to researches, people feel safer for the possible devastating effects of the risk while their perceived level of control is increasing. Also, the decreasing level of control brings a higher level of perceived risk (Gerend et al., 2004).

At the end of the 1990s, researchers have focused on the differences based on the sex for the perceived risk (For example, Andresen, 2000; Arch, 1993; Byrnes et al., 1999; Schubert et al., 1999). According to these researches, the perceived risk structure of the women is more layered and they are more intend to take the risk than men. On the other hand, men evaluate the risks by relating them with dangers (Hawkes and Rowe, 2008; Boholm, 1998).

Many people lean on their past experiences and knowledge while perceiving the risk. In some circumstances, people may have no experience or any information about the situation. In this case, they may apply to different resources to obtain information about the risk. The reliability of these resources is a substantial concern and determinant of the perceived risk for people (Williamson ve Weyman, 2005). Manipulated information may distort the evaluation of the people and lead to a wrong perception of the risk.

Age has a substantial impact on the perceived risk. For instance, people have an increased risk of health while they are getting older. In this case, their level of perceived risk may change. Gerend et al. (2004) assert that older women have lover risk perception for breast cancer and heart disease risks.

1.3.Perceived Risk in Pregnancy

The concept of risk perception also provides a basis for the formation of some theories about the health-related behaviors of people. Examples of these are the "Health Belief Model" of Janz and Becker (1984), the "Protection Motivation Theory" of Maddux and Rogers (1983), and the "Expectation Theory" of Kahneman and Tversky (1979). Most of these theories are based on the assumption that the individual analyzes potential risks and possible benefits by making a rational set of analyzes on health-related issues. In this study, the concept of risk is used to mean existing or perceived medical risk.

In recent years, easier access to information on the internet and many developments in the field of health have brought the risk of pregnancy higher on the agenda (Carolan, 2003). With the increasing rate of women using communication technologies, their possibility of being exposed to wrong information increases. "High-risk pregnancy" is a type of pregnancy that includes many possibilities beyond the general pregnancy situation that may have negative consequences for the mother or baby (James & Stirrat, 1988) and should not be confused with the perception of risk in pregnancy.

While high-risk pregnancy is a medical reality, the perception of risk in pregnancy is a result of the pregnant woman's subjective assessment of her situation.

According to Heaman et al. (2004), as in other types of risk, the risk of pregnancy is also very personal and is affected by many different factors. Women and healthcare professionals are defining the risk in different ways. Healthcare providers define risk based on their knowledge, education, experience, and values. On the other hand, women interpret risk more individually and judge by their situation (Handwerker, 1994). In doing so, they may be under the influence of their values, education, and even their social class (Searle, 1996; Saxell, 2000).

Johanson et al. (2002) state that women's wishes and fears should be taken into account to provide a clinically efficient service. There is evidence about the effect of changing risk perception during pregnancy on the healthcare consumption and prenatal care-seeking of pregnant women. Blankson et al. (1994) assert that there is a contradiction between the level of the perceived risk of women who had a high-risk pregnancy and the antenatal care providers'. They also indicate that this has a significant impact on neglected antenatal care appointments. In another study conducted by examining the data collected from 51 women with a qualitative method, Atkinson et al. (1995) evaluated the pregnancy risk perception of pregnant women in Brazil and their motivation to benefit from health services. According to the findings of this study, the substantial risks in pregnancy from the perspective of women are; cesarean section, abortion (planned or unplanned), high blood pressure, and anemia (Atkinson et al., 1995). On the other hand, the risk perception of women is not always related to medical diagnosis. Sometimes, they may express this with their comments rather than medical models. Besides, the perceived risk level of the women is also dependent on the health service they receive and the current conditions of their environment.

Kolker and Burke (1993) state there is a relationship between risk perception and prenatal diagnosis processes. Suplee et al. (2007) state that women's risk perception impacts choosing the place of delivery and deciding on the medical interventions to be exposed to. Kowalewski et al. (2000), on the other hand, argue that women can ignore even the wages and distances to reach the prenatal service they prefer depending on the risk level they perceive.

Literature defines many factors that have an impact on the perceived risk in the pregnancy. Heaman et al. (2004) tried to define the factors that pregnant women consider in their risk assessment in a qualitative study. According to the researchers', the risk assessment process is a multidimensional structure that includes self-esteem, family health history, health system, and unrecognizable and unknown problems arising from health status. According to the results of this study, women who see themselves as healthy have a lower level of risk perception, while it's the opposite for the ones who feel they are not healthy. Also, researchers indicate that the health history, current health state, previous pregnancies, and health history of the family members of the participants have a significant impact on their evaluation processes.

The most obvious and negative effect of increased risk perception during pregnancy is increased stress and process-related concerns. It will not be surprising that stress and anxiety that increase during pregnancy also affect the baby after birth (O'Connor et al., 2002; Robinson et al., 2011; Yehuda et al., 2002). It is known that a high level of stress during pregnancy increases early and/or low birth weight and similar adversities (Dole et al., 2003; Talge et al., 2007; Wadhwa et al., 2001). Robinson et al. (2011) stated that situations that cause stress do not always have to be traumatic. They state that issues such as material problems in daily life, difficulties in relationships, and general difficulties in life can also cause such results (Robinson et al., 2011).

Increased risk perception during pregnancy affects not only the expectant mother, but also all her family members (Robinson et al., 2011). The perception of high risk increases anxiety disorders in the family, and traumatic prenatal experiences may take quite a long time to resolve, and even this dissolution process may cause the newborn to be exposed to an environment surrounded by stress after birth (Sanz et al., 2001; Waldenstrom, 2004).

Atkinson et al. (1995) state that the socio-economic status of pregnant women and the nature of the health services they benefit from also have an impact on the level of risk they perceive.

Patterson (1993) states that women may form an opinion about the risky issues of their pregnancy based on their evaluations of the institutions that provide health services.

Gupton et al. (2001) tried to determine the relationship between biomedical, psychological, and demographic risk factors and pregnancy risk by using qualitative method. They found that biomedical risk and state anxiety are determinative in terms of pregnancy risk. They also found the risk perceived by women in problematic pregnancies is higher than in normal pregnancies. In another study, it is stated that pregnant women's confidence level in the health services they receive is also related to the perceived risk of pregnancy (Heaman et al., 2004). In Patterson's (1993) study on black women, the risk of pregnancy perceived by this group is not only based on their experiences and evaluating the healthcare they receive. It is also based on the feedback they have received from other black women. According to the findings of the study of Conseil Sante et al. (2007), women are attaching importance to the information from the other experienced women who had a pregnancy before. They also indicate that in some conditions, women may care for those pieces of advice more than the ones from the healthcare providers (Conseil Sante et al., 2007).

There may be many different adversities that women may encounter during pregnancy at advanced ages (Cleary-Goldman et al., 2005; Jacobsson et al., 2004; Joseph et al., 2005; Bayrampour et al., 2007). According to Carolan and Nelson (2007), the risks of pregnant women at an advanced age can be based on psychological, medical, and social issues. In the study conducted by Tough et al. (2006) on 1044 women selected by random sampling, low-weight delivery, preterm birth, and multiple births were found as possible risks for the women who got pregnant at an advanced age. Windridge (1999) found in his study that pregnant women over the age of 35 know more about the risks associated with pregnancy than women aged 20-29. It is said that there is a statistically significant and positive relationship between age and pregnancy responsibility and paying attention to nutrition, and a negative correlation between physical activity (Yılmaz & Karahan, 2019). It can be said that the decrease in physical activity is related to the women avoiding heavy work and intense physical activity during pregnancy due to possible risks (Conseil Sante, 2007).

In some other studies, it is stated that women who have concerns about the health of their unborn children show depressive tendencies during their pregnancy (Georgsson et al., 2009). Women with this type of mood may face negative consequences for their children before or after birth (Federenko & Wadhwa, 2004; Markus and Miller, 2009; Robinson et al., 2008).

In studies on antidepressant use during pregnancy, it has been found that there is a strong belief that women use antidepressants during pregnancy may cause some congenital anomalies in the child (Bonari et al., 2005; Koren & Nordeng, 2012).

Lima Perreira et al. (2002) found that 97.7% of the participating pregnant women stated that they researched on the internet in the last 24 hours to obtain information about the pregnancy issues.

On the other hand, it is known that this type of information, which is not filtered through skepticism or accepted as correct without consulting with clinicians, has a disproportionate and bad effect on pregnant women (Enkin & Jadad, 1998). Since the information circulating in virtual environments is mostly not verified, most of them cause people to be misled. It is also known that some women started to experience anxiety disorders and stress as a result of the research they conducted over the internet and that they quit that research behavior because of the negative mood that causes (Bayrampour et al., 2012).

One of the negativities caused by the increase in risk perception during pregnancy is the deterioration of the relationship between the pregnant woman and the people who provide her health care. This situation usually occurs as a result of misunderstandings in communication as a result of inconsistency in attitudes during pregnancy (Lee et al., 2012). In some cases, the patient's concerns may exceed the objective medical risk level. In such cases, it has been observed that pregnant women stress themselves by taking unnecessary precautions regarding their pregnancy (Carolan, 2009; Lee et al., 2012).

Managing depression, anxiety, and stress during pregnancy is an important issue for women in both low and high-risk groups (O'Brien et al., 2010). Pregnant women can manage risk factors easier and make the right decisions with psychosocial support and their physicians. To achieve this, the self-efficacy of pregnant women can be increased with the help of training about the pregnancy. Studies are showing that high self-efficacy is also associated with better parenting performance. Therefore, it is possible to say that increasing self-efficacy is also beneficial for postpartum (Coleman & Karraker, 1998). Experiential information can increase the negative effect and even make it uncontrollable for women who have experienced problematic pregnancy before (Jordan & Murphy, 2009).

There are also researches about the insensitivity of women through the perceived risks of pregnancy. These studies assert that perceived risk is not always realized as an action or precaution. For example, in a study on pregnancy-related diabetes, it is stated that as age increases, the perceived risk of developing the disease increases, but this does not cause the women to choose a healthier lifestyle (Noronha, 2018). In another study, it is stated that women do not have a significant difference in their attitudes towards smoking during pregnancy, although they have information about the risks they may pose (Show et al., 2019: 7). Therefore, it is not possible to state that the increase in the perceived risk level will result in a behavioral change and will decrease for every case.

2.METHOD

The research is an exploratory study, and its ultimate aim is to reveal a measurement tool on the effect of risk perception in pregnancy on the choice of maternity insurance. From this point of view, a data collection form based on the following concepts in the literature was developed. Also, the opinions of three academic staff from the field of health sciences were asked:

- Risk knowledge: The first concept for perceived risk in the psychometric model is knowledge of risk or familiarity with risk (Boholm, 1998; Fischhoff et al., 1978; Williamson & Weyman, 2005).
- Fear factor: The second concept is the fear factor observed in women who have high levels of anxiety to have a healthy pregnancy with desired results (Gupton et al., 2011).

- Medical risk: It would be appropriate to say that the medical risk perception is based on the medical history of the individual and his family (Gerend et al., 2004; Heaman et al., 2004). On the other hand, Atkinson et al. (1995) argue that the medical risk perceived by patients may not always be compatible with modern medicine.
- Health status: Heaman et al. (2004) state that a woman's current health status also determines her perceived risk when evaluating her pregnancy.
- Cognitive intuitions: Cognitive intuitions are road maps used to scan and reach risk information in the mind (Boholm, 1998). According to Gerend et al., This concept is "a shortcut that facilitates access to past experiences and examples to use in calculating the probability of a situation happening" (Gerend et al., 2004: 248).
- Perceived control: If an individual has measurable control over a potential risk, they may perceive the situation as less risky than it actually is. In other words, a controllable risk, although at a high level, can be perceived as a lower threat than others (Nordgren et al., 2007). In the study of Kolker and Burke (1993), prenatal risk perception and perceived control in relation to decision making, the effect of the result (fear factor), and psychological tendency to risk can affect the risk perception.

The population of the research is composed of Turkish female consumers. According to Anadolu Agency (February 2020), the total population for this research is 41.433.861. Therefore, for this study, it is necessary to collect data from at least 384 people according to Balci's (2013) sample size table at 95% confidence level.

An online form was set to collect data, and a total of 472 valid forms were obtained. Data collection was made between September 1 and November 20, 2019. The convenience sampling method was applied for this phase. In the explanation part of the data collection form, that was stated that participating in the research is a voluntary decision. Five point Likert scale was applied for the data collection form.

Frequency analysis was applied through the SPSS 22 package program in order to understand the demographic characteristics of the participants, and then factor analysis was applied to understand the measurement capability and dimensions of the questionnaire. Subsequently, in order to reveal the construct validity of the result obtained as a result of the factor analysis, confirmatory factor analysis was carried out with the AMOS program and the Cronbach's Alpha value was determined by the SPSS 22 package program to determine the reliability level of the obtained structure.

Since the research was not funded by any sponsor, it has limitations such as the convenience sampling method, the participants being limited to Ankara, and the data having to be collected in a short time.

3.FINDINGS

Results of the frequency, reliability, exploratory and confirmatory factor analysis results are shared in this section.

3.1.Frequency Analysis of the Demographical Variables

Prominent findings for the women who participated in the research are given in Table 1.

Table 1: Frequency Analyze

Average Age	37,76
Average Income	4837 TL
University Grad.	%59,40
Employed	%88,50

Table 1 shows that the participants are well educated middle-aged women who have middle income who are currently employed.

3.2. Factor Analysis

Factor loads, explained total variance, and variances are given in Table-2.

Table 2: Factor Analysis

Dimension	Item	Mean	Factor Load	Var. Exp.
Dimension (1) [Accessible Healthcare Services]	I think that the service I have with the birth insurance will help me go through my pregnancy more unproblematic.	3,60	0,912	32,026
	I think the quality of the medical service I will receive will be better by courtesy of the maternity insurance.	3,60	0,843	
	It comforts me to know that I can get many different services by courtesy of maternity insurance.	3,91	0,833	
	My family and social environment will also think that I am safer if I get maternity insurance.	3,48	0,822	
	If I receive maternity insurance, I will determine which medical service provider I will choose with detailed research.	4,11	0,702	
	If I choose maternity insurance, it is because my baby's health is more important than mine.	3,73	0,660	
	If I choose maternity insurance, it is because my health is more important than anything else.	3,64	0,645	
Dimension (2) [Information Resources for Health Problems]	Whenever I have a hesitation about my health, I consult many people about my concerns.	3,06	0,829	14,409
	If I have any hesitation about my pregnancy, I do research about my concerns on the internet.	3,56	0,749	
	When it comes to pregnancy, I am impressed by what people around me say.	2,79	0,728	
Dimension (3) [Health History]	If I choose maternity insurance, it will be because of my family's health history.	2,71	0,903	12,807
	If I choose maternity insurance, it will be because of my health history.	2,90	0,874	
Dimension (4) [Experiences about Health]	When it comes to pregnancy, I trust my physician's opinion without question.	2,99	0,877	10,36
	When it comes to pregnancy, my past health experiences are decisive in my decisions.	3,52	0,574	
Total Variance Explained			%69,60	

As can be seen from Table 2, the structure is consisting of 14 questions and four dimensions. This structure explains approximately 70% of the total variance. Hair et al. (2012) recommended that

the total variance explained value should be over 60%. Therefore, it can be said that the total variance explained value is sufficient.

The first dimension consists of seven items that define the perspectives of women on access to safer health services by courtesy of maternity insurance. The second dimension of the questionnaire consists of three items and indicates the sources used in the search for information in case of hesitation about health. According to this, when women have doubts about their health status, they consult many different people, search the internet, and are affected by what people around them tell. According to the findings, the health history of the woman and her family constitutes a dimension consisting of two items related to the preference of maternity insurance. It is understood from this that women consider the health history of their families and themselves as a reference point in the perceived risk of their pregnancy. In the fourth and last dimension, two items are expressing the woman's confidence in her own experiences and the competencies of the physician she receives.

3.3. Confirmatory Factor Analysis

Confirmatory factor analysis has been applied to test the structure obtained from the exploratory factor analysis that has 4 dimensions with 14 items. The result is given as a diagram in Image 1.

Image 1: Confirmatory Factor Analysis

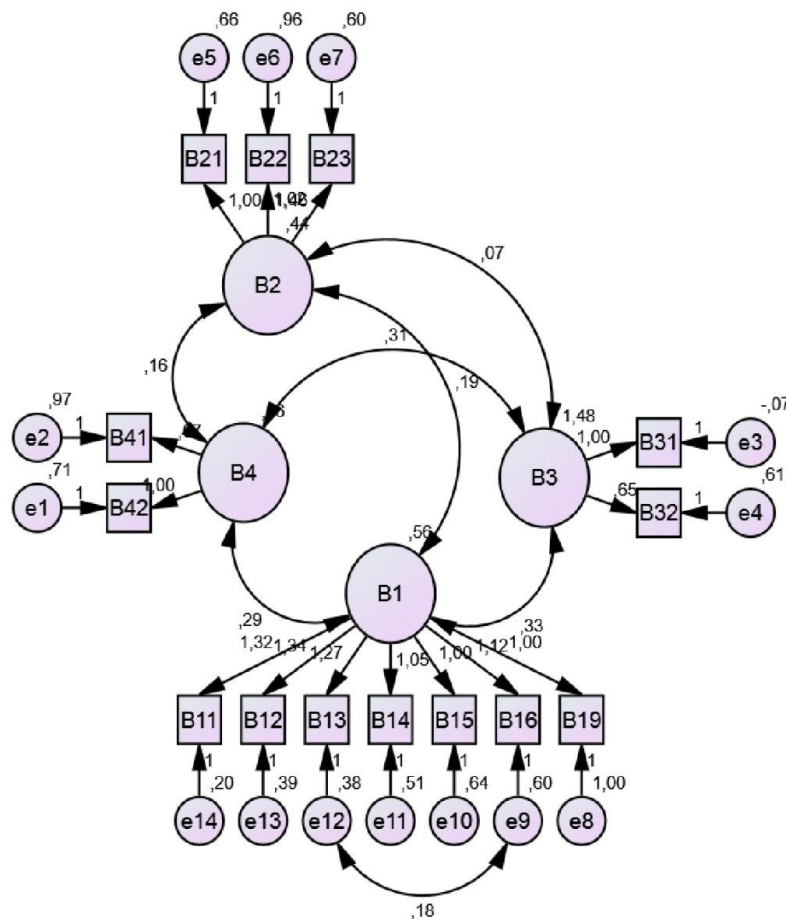

According to the analysis results, all the fit indices (CMIN/DF, CFI, GFI ve RMSEA) were between acceptable limits. That proves that the questionnaire has structural validity. Table 3 shows the fit indices values for this questionnaire and the reference limits.

Table 3: Fit indices and acceptable limits

Fit indice	Value	Limits	Reference	Result
CMIN/DF	1,49	CMIN/DF<2	Reinard, 2006	Between acceptable limits
CFI	0,943	CFI>0,90	Çapık, 2014	Between acceptable limits
GFI	0,911	GFI>0,90		Between acceptable limits
RMSEA	0,072	0,05<RMSA<0,08	Noudoostbeni et al., 2018	Between acceptable limits
Cronbach's Alpha	0,854	Cr.A>0,60	Hair et al., 2010	Between acceptable limits

The Cronbach's Alpha value of the questionnaire was calculated as 0,854. In general, 0.60 and above are accepted as reliable results. Based on this, this questionnaire can be accepted as a reliable tool.

DISCUSSION AND CONCLUSION

A reliable and structurally valid questionnaire with four dimensions and 14 questions has been developed for measuring the thoughts of women about maternity insurance within the scope of this research.

Results of the analysis were corroborating to the current literature. According to these results, female consumers can agree to pay extra for the prenatal care they want (Kowalewski et al., 2000), anxiety that increases during pregnancy may have a negative impact on family members and themselves (Robinson et al., 2011), they may want to act more freely in deciding where to give birth in parallel with the increased perception of risk associated with pregnancy (Suplee et al., 2007), when they are in doubt about their pregnancy or health, they seek information from the internet or their social environment (Patterson, 1993; Lima Perreira et al., 2002; Conseil Sante et al., 2007), the risk they perceive about the pregnancy is also affected by the health history of themselves and their families (Heaman et al., 2004). In addition to these, it is understood that women consider the health of both themselves and the baby they are carrying in their preferences to purchase maternity insurance, they can choose to rely on their past experiences and the guidance of their physicians regarding their health, and they think that they increase the quality and reliable choice alternatives thanks to the maternity insurance.

Female consumers may purchase maternity insurance to protect their health after the baby they carry. They believe they will have a more problem-free pregnancy by easily accessing different and high-quality health services during the pregnancy process in this way. Thus, it can be said that their families and social environment think that the pregnancy will proceed safely. Besides, it is understood that the participants will choose among alternative medical service providers after a detailed examination if they receive maternity insurance. On the other hand, female consumers seem to make their decisions based on their past health experiences with their internet research findings if they feel any problems about their pregnancy.

Therefore, it is considered that the research can help insurance service providers to be more effective in their marketing activities by shaping the channels and messages to be used to reach female consumers in the light of this information.

Researchers can apply the scale with self-esteem, personality, values, attitudes, brand, decision making, purchasing motivation, word of mouth scales, and demographical variables. They can also apply the scale with different populations for further studies.

REFERENCES

Please check the links for references:

- <https://dergipark.org.tr/tr/pub/bsad/issue/55816/734539>
- https://www.researchgate.net/publication/342872475_Dogum_Teminati_Sigortasi_Tercihinde_Hamilelikte_Risk_Algisinin_Etkisi_Kadin_Tuketiciler_Uzerine_Bir_Arastirma_Effect_of_Perceived_Risk_at_Pregnancy_on_the_Maternity_Insurance_Choice_A_Research_on_Fema
- https://www.academia.edu/43589340/Do%C4%9Fum_Teminat%C4%B1_Sigortas%C4%B1_Tercihinde_Hamilelikte_Risk_Alg%C4%B1s%C4%B1n%C4%B1n_Etkisi_Kad%C4%B1n_T%C3%BCketiciler_%C3%9Czerine_Bir_Ara%C5%9Ft%C4%B1rma_Effect_of_Perceived_Risk_at_Pregnancy_on_the_Maternity_Insurance_Choice_A_Research_on_Female_Consumers

Cite as: Baltacı, A. (2020). Doğum Teminatı Sigortası Tercihinde Hamilelikte Risk Algısının Etkisi: Kadın Tüketiciler Üzerine Bir Araştırma. Bankacılık ve Sigortacılık Araştırmaları Dergisi, (14), 26-43. Retrieved from: <https://dergipark.org.tr/tr/pub/bsad/issue/55816/734539>.

REFERENCES

Please check the links for references:

- <https://dergipark.org.tr/tr/pub/bsad/issue/55816/734539>
- https://www.researchgate.net/publication/342872475_Dogum_Teminati_Sigortasi_Tercihinde_Hamilelikte_Risk_Algisinin_Etkisi_Kadin_Tuketiciler_Uzerine_Bir_Arastirma_Effect_of_Perceived_Risk_at_Pregnancy_on_the_Maternity_Insurance_Choice_A_Research_on_Fema
- https://www.academia.edu/43589340/Do%C4%9Fum_Teminat%C4%B1_Sigortas%C4%B1_Tercihinde_Hamilelikte_Risk_Alg%C4%B1s%C4%B1n%C4%B1n_Etkisi_Kad%C4%B1n_T%C3%BCketiciler_%C3%9Czerine_Bir_Ara%C5%9Ftma_Effect_of_Perceived_Risk_at_Pregnancy_on_the_Maternity_Insurance_Choice_A_Research_on_Female_Consumers

Cite as: Baltacı, A. (2020). Doğum Teminatı Sigortası Tercihinde Hamilelikte Risk Algısının Etkisi: Kadın Tüketiciler Üzerine Bir Araştırma. Bankacılık ve Sigortacılık Araştırmaları Dergisi, (14), 26-43. Retrieved from: <https://dergipark.org.tr/tr/pub/bsad/issue/55816/734539>.

REFERENCES

Please check the links for references:

- <https://dergipark.org.tr/tr/pub/bsad/issue/55816/734539>
- https://www.researchgate.net/publication/342872475_Dogum_Teminati_Sigortasi_Tercihinde_Hamilelikte_Risk_Algisinin_Etkisi_Kadin_Tuketiciler_Uzerine_Bir_Arastirma_Effect_of_Perceived_Risk_at_Pregnancy_on_the_Maternity_Insurance_Choice_A_Research_on_Fema
- https://www.academia.edu/43589340/Do%C4%9Fum_Teminat%C4%B1_Sigortas%C4%B1_Tercihinde_Hamilelikte_Risk_Alg%C4%B1s%C4%B1n%C4%B1n_Etkisi_Kad%C4%B1n_T%C3%BCketiciler_%C3%9Czerine_Bir_Ara%C5%9Ft%C4%B1rma_Effect_of_Perceived_Risk_at_Pregnancy_on_the_Maternity_Insurance_Choice_A_Research_on_Female_Consumers

Cite as: Baltacı, A. (2020). Doğum Teminatı Sigortası Tercihinde Hamilelikte Risk Algısının Etkisi: Kadın Tüketiciler Üzerine Bir Araştırma. Bankacılık ve Sigortacılık Araştırmaları Dergisi, (14), 26-43. Retrieved from: <https://dergipark.org.tr/tr/pub/bsad/issue/55816/734539>.

REFERENCES

Please check the links for references:

- <https://dergipark.org.tr/tr/pub/bsad/issue/55816/734539>
- https://www.researchgate.net/publication/342872475_Dogum_Teminati_Sigortasi_Tercihinde_Hamilelikte_Risk_Algisinin_Etkisi_Kadin_Tuketiciler_Uzerine_Bir_Arastirma_Effect_of_Perceived_Risk_at_Pregnancy_on_the_Maternity_Insurance_Choice_A_Research_on_Fema
- https://www.academia.edu/43589340/Do%C4%9Fum_Teminat%C4%B1_Sigortas%C4%B1_Tercihinde_Hamilelikte_Risk_Alg%C4%B1s%C4%B1n%C4%B1n_Etkisi_Kad%C4%B1n_T%C3%BCketiciler_%C3%9Czerine_Bir_Ara%C5%9Ftma_Effect_of_Perceived_Risk_at_Pregnancy_on_the_Maternity_Insurance_Choice_A_Research_on_Female_Consumers

Cite as: Baltacı, A. (2020). Doğum Teminatı Sigortası Tercihinde Hamilelikte Risk Algısının Etkisi: Kadın Tüketiciler Üzerine Bir Araştırma. Bankacılık ve Sigortacılık Araştırmaları Dergisi, (14), 26-43. Retrieved from: <https://dergipark.org.tr/tr/pub/bsad/issue/55816/734539>.

REFERENCES

Please check the links for references:

- <https://dergipark.org.tr/tr/pub/bsad/issue/55816/734539>
- https://www.researchgate.net/publication/342872475_Dogum_Teminati_Sigortasi_Tercihinde_Hamilelikte_Risk_Algisinin_Etkisi_Kadin_Tuketiciler_Uzerine_Bir_Arastirma_Effect_of_Perceived_Risk_at_Pregnancy_on_the_Maternity_Insurance_Choice_A_Research_on_Fema
- https://www.academia.edu/43589340/Do%C4%9Fum_Teminat%C4%B1_Sigortas%C4%B1_Tercihinde_Hamilelikte_Risk_Alg%C4%B1s%C4%B1n%C4%B1n_Etkisi_Kad%C4%B1n_T%C3%BCketiciler_%C3%9Czerine_Bir_Ara%C5%9Ftma_Effect_of_Perceived_Risk_at_Pregnancy_on_the_Maternity_Insurance_Choice_A_Research_on_Female_Consumers

Cite as: Baltacı, A. (2020). Doğum Teminatı Sigortası Tercihinde Hamilelikte Risk Algısının Etkisi: Kadın Tüketiciler Üzerine Bir Araştırma. Bankacılık ve Sigortacılık Araştırmaları Dergisi, (14), 26-43. Retrieved from: <https://dergipark.org.tr/tr/pub/bsad/issue/55816/734539>.

REFERENCES

Please check the links for references:

- <https://dergipark.org.tr/tr/pub/bsad/issue/55816/734539>
- https://www.researchgate.net/publication/342872475_Dogum_Teminati_Sigortasi_Tercihinde_Hamilelikte_Risk_Algisinin_Etkisi_Kadin_Tuketiciler_Uzerine_Bir_Arastirma_Effect_of_Perceived_Risk_at_Pregnancy_on_the_Maternity_Insurance_Choice_A_Research_on_Fema
- https://www.academia.edu/43589340/Do%C4%9Fum_Teminat%C4%B1_Sigortas%C4%B1_Tercihinde_Hamilelikte_Risk_Alg%C4%B1s%C4%B1n%C4%B1n_Etkisi_Kad%C4%B1n_T%C3%BCketiciler_%C3%9Czerine_Bir_Ara%C5%9Ft%C4%B1rma_Effect_of_Perceived_Risk_at_Pregnancy_on_the_Maternity_Insurance_Choice_A_Research_on_Female_Consumers

Cite as: Baltacı, A. (2020). Doğum Teminatı Sigortası Tercihinde Hamilelikte Risk Algısının Etkisi: Kadın Tüketiciler Üzerine Bir Araştırma. Bankacılık ve Sigortacılık Araştırmaları Dergisi, (14), 26-43. Retrieved from: <https://dergipark.org.tr/tr/pub/bsad/issue/55816/734539>.

REFERENCES

Please check the links for references:

- <https://dergipark.org.tr/tr/pub/bsad/issue/55816/734539>
- https://www.researchgate.net/publication/342872475_Dogum_Teminati_Sigortasi_Tercihinde_Hamilelikte_Risk_Algisinin_Etkisi_Kadin_Tuketiciler_Uzerine_Bir_Arastirma_Effect_of_Perceived_Risk_at_Pregnancy_on_the_Maternity_Insurance_Choice_A_Research_on_Fema
- https://www.academia.edu/43589340/Do%C4%9Fum_Teminat%C4%B1_Sigortas%C4%B1_Tercihinde_Hamilelikte_Risk_Alg%C4%B1s%C4%B1n%C4%B1n_Etkisi_Kad%C4%B1n_T%C3%BCketiciler_%C3%9Czerine_Bir_Ara%C5%9Ft%C4%B1rma_Effect_of_Perceived_Risk_at_Pregnancy_on_the_Maternity_Insurance_Choice_A_Research_on_Female_Consumers

Cite as: Baltacı, A. (2020). Doğum Teminatı Sigortası Tercihinde Hamilelikte Risk Algısının Etkisi: Kadın Tüketiciler Üzerine Bir Araştırma. Bankacılık ve Sigortacılık Araştırmaları Dergisi, (14), 26-43. Retrieved from: <https://dergipark.org.tr/tr/pub/bsad/issue/55816/734539>.